

WHITEPAPER

HOW DC COUPLING CAN INCREASE THE EFFICIENCY OF POWER PLANTS

A new flexibility and ease for the connection of storage at PV power plants



As the proportion of renewable energy in utility grids continues to grow worldwide, large storage systems are becoming an increasingly important issue.

Until now, AC-coupled systems have been the means of choice for coupling large battery storage systems to PV power plants for due to lower costs. These involve two or more energy systems (PV and storage systems or only storage systems) working separately from one another on the DC side. The energy paths are then coupled together on the AC side upstream of the connection to the medium-voltage grid / Point of Interconnection (POI), hence the name of AC coupling. With DC coupling, the PV array and the battery storage system are connected to one another on the DC side of the inverter. As a result, the battery inverter as well as an additional transformer and medium-voltage switchgear are no longer required. Short cable routes minimize energy losses in the lines – the entire system becomes even more efficient. Fewer components, less cabling; with DC-coupled systems, PV system operators save on investment costs.

Each solar energy system consists of an inverter, a medium-voltage transformer and usually a medium-voltage switchgear which are connected to either a PV array (module array) or a battery storage system on the DC side.

This entire system is controlled and regulated via a PV Power Plant Controller in relation to the individual grid requirements at the POI.

DC or AC coupling

The main field of application for AC-coupled battery storage systems is extended grid management services, such as:

- Peak load shaving (AC coupling)
- Avoidance of grid extension (AC coupling)
- Reactive power compensation (DC and AC coupling)
- Primary reserve control (AC coupling)
- Energy shifting (DC and AC coupling)

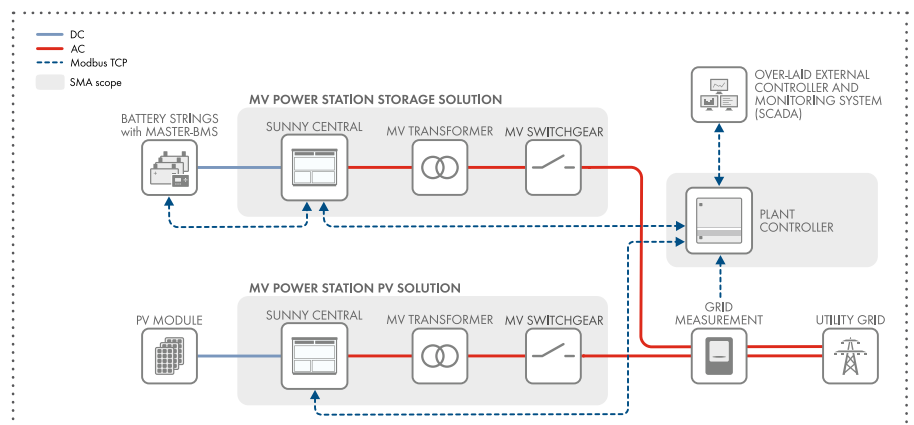

AC-coupled PV + storage system

DC COUPLING OPTIONS AND BENEFITS

With DC coupling, the battery and the PV array are connected to a central inverter on the DC side. The central inverter is then connected to a MV transformer to complete the system.

Benefits:

- System costs are minimized as there are fewer components (no separate inverters or transformers are needed for the battery storage system)
- Energy losses in conversion and storage are reduced
- Full load hours are optimized

A further benefit of DC coupling is that installation is faster since the system is made up of fewer components. This also means lower maintenance costs.

NEW OPTIONS:

Ramp rate control

Greater changes in irradiation / fluctuations can be reduced via the battery system and follow a defined power ramp in both

directions for increasing and reducing power. This ensures that the amount of energy required is available at all times.

PV smoothing

Short, rapid changes and fluctuations in irradiation can be smoothed/balanced out via the battery system.

Clipping recapture

If the current PV array power exceeds that of the inverter, the surplus energy is stored in the batteries on the DC side, while the inverter can continue to operate under full load. The energy stored can be used to extend the operating time for the inverter that day, sold on the energy market at

a later time or discharged once more through time-of-use tariffs.

Frequency support

The inverter supports the utility grid with active power if the grid frequency drops. Through the battery system, the inverter can support the utility grid in the event of a failure more independently of the current solar irradiation.

Connecting larger units

The principle of DC coupling enables overdimensioning of the PV arrays used or a higher power class in the central inverters to increase yield.

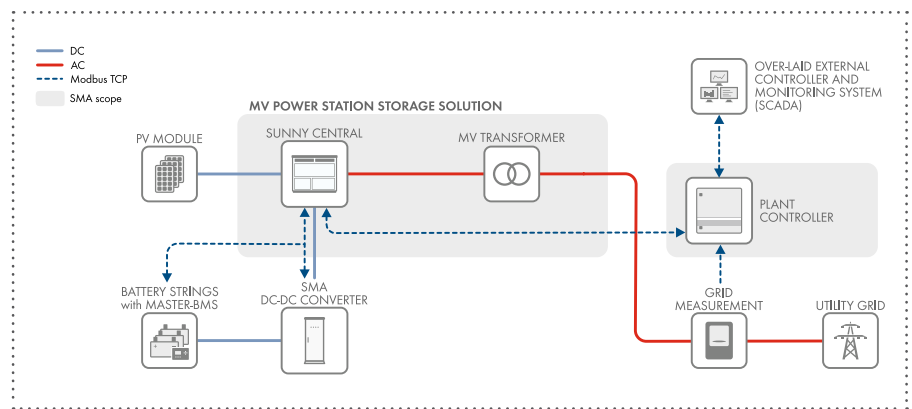

DC-coupled PV + storage system

NEW BUSINESS MODELS

Besides optimizing the full load hours of the inverters, using DC coupling to connect battery storage systems to PV power plants opens up new fields of application and makes attractive business models possible for PV system operators.



NEW MILESTONE: GRID-FORMING AND BLACK START CAPABILITY

“With the grid-forming feature and black start capability, PV power plants can be used to guarantee the base load. They not only synchronize with an existing grid voltage as before, but can also supply this themselves. They can gradually replace conventional power plants – a milestone on the road to a 100% renewable energy supply.”

THE SMA SYSTEM FOR DC-COUPLED BATTERY STORAGE

Sunny Central

Sunny Central central inverters are available for delivery with up to six DC input terminals for batteries. The optional terminals connect directly to the main busbar in the central inverter between the DC switch and the inverter bridge. The PV field can thus be disconnected from the central inverter at night, while the battery is charged or discharged via the AC side (on the grid side).

Voltage converter

With the SMA DC-DC converter, the DC voltage can be increased or decreased slightly to control the direction of energy flow to the battery. If the voltage is increased slightly at the converter, the battery will be charged. If it is reduced, the battery will discharge.

Communication and control

The SMA DC coupling system consists of a central inverter, an SMA DC-DC converter, a battery storage system and a Battery Management System (BMS). The DC-DC converter and the BMS are connected to the main communication of the central inverter. The charging and discharging of the battery can be controlled directly through the customer-specific SCADA system via Modbus.

MAXIMUM FLEXIBILITY FOR SIMPLE STORAGE CONNECTION

The new Sunny Central UP is the first central inverter to offer the option of integrating hardware and software solutions for connecting both AC- and DC-coupled storage systems. This allows an exceptionally high level of design flexibility for PV power plants in the megawatt class.

Depending on the project requirements, storage solutions can be connected within the PV power plant on the DC side, the AC side or even both – directly during the construction of the power plant or during subsequent expansion.

The “DC Coupling Ready” option offers the possibility of obtaining a Sunny Central central inverter with six battery inputs. This means that a battery storage system coupled on the DC side can be retrofitted easily and cost-effectively at any time – when battery prices have fallen further, for example.

Central Inverter
Sunny Central UP
Power class up to 4,600 kVA



ENERGY
THAT
CHANGES



Andreas Tügel
Product Manager Central Power Conversion

SMA Solar Technology AG
Sonnenallee 1
34266 Niestetal
Phone: +49 561 9522-0
Email: Info@SMA.de
www.SMA.de

SOCIAL MEDIA
www.SMA.de/newsroom

